

REVISION RECORD

REV	ECN	DESCRIPTION	DRFT	DATE
-----	-----	-------------	------	------

NOTES1:

UL Standard

- 1.Rated voltage/current : 300V / 15A
- 2.Withstanding voltage : AC1600V/1Min.

IEC Standard

1. Pollution Degree	3
Overvoltage Category	III
Rate Impulse Voltage(KV)	4.0KV
Rate Voltage(V)	400V
Rate Current(A)	20A

NOTES2:

- 1.Dimension shall be interpreted per ASME Y14.5-2009
- 2.Pitch : 7.50mm, Poles : N=02~12P
- 3.Operating temperature:-40°C~+105°C
- 4.Undimensioned tolerances:

Pitch range in mm	Nominal dimension range in mm						0.1/10	
	Over 6 TO 10	Over 10 TO 24	Over 30 TO 60	Over 60 TO 100	Over 100 TO 150	Over 150		
±0.15	±0.20	±0.30	±0.30	±0.50	±0.70	±1.00	±1.30	±2'

5.RoHS Compliance

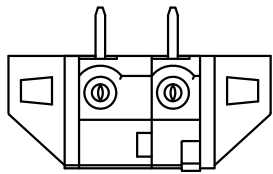
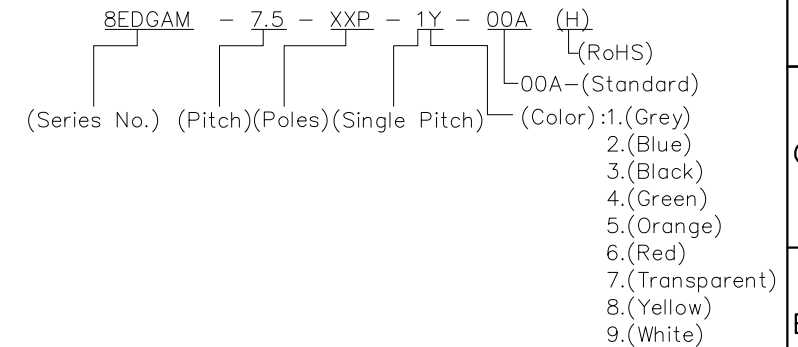

02P

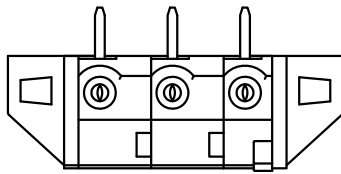

03P

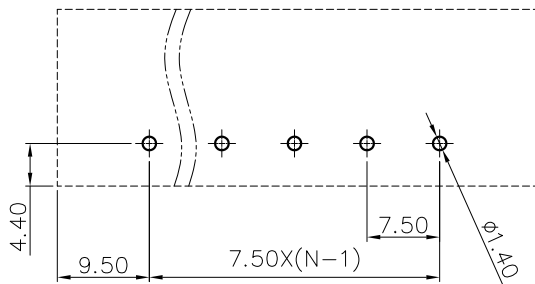
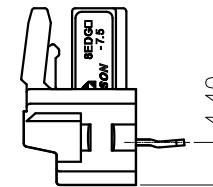
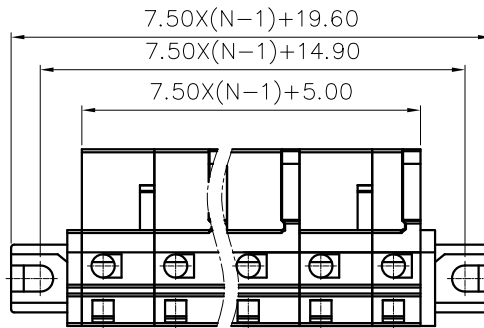
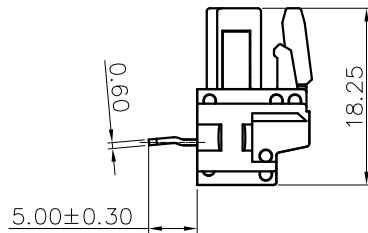
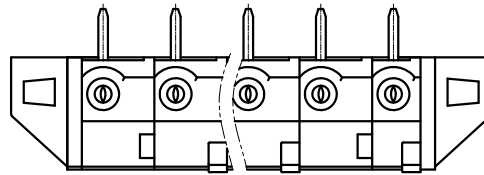

P.C.B LAYOUT

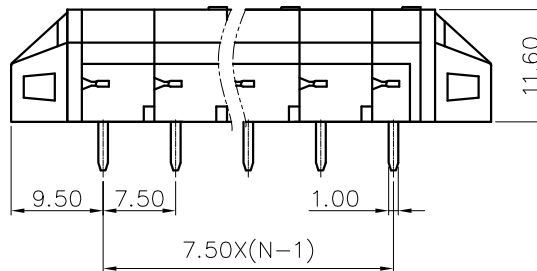

DETACHED LISTS	PART NO.:	/			
	APPD:	/			
	CHKD:	/			
	DRFT:	/			
	THIRD ANGLE PROJECTION		DRAWING NO.:		/
		NAME:		NINGBO DEGSON ELECTRICAL CO., LTD	
		TITLE:		CUSTOMER DRAWING	
		REVISION:		REV: / DO: /	
		SCALE:		1:1	